

# Fitting Instructions

Model: MOK6/MOKA

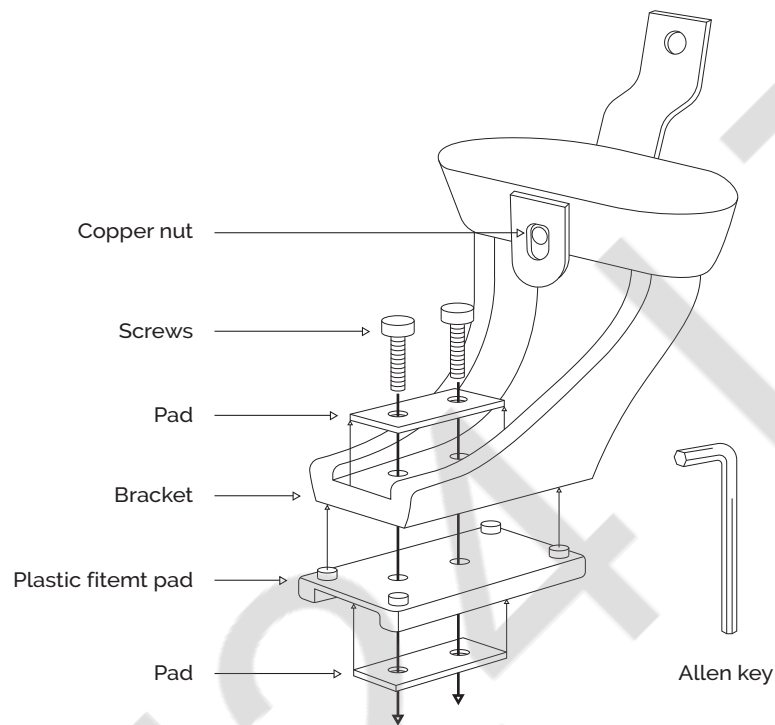

## Parts:



## Bar types:

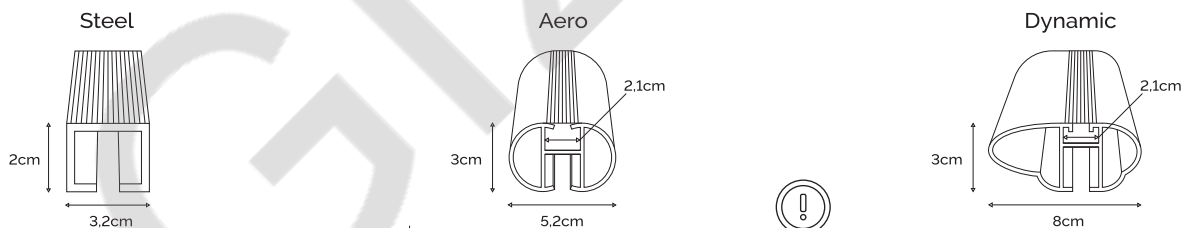

Please use additional rubber and fill in visible slots underneath the bar.

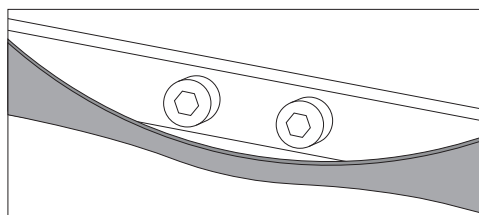

## Manual:

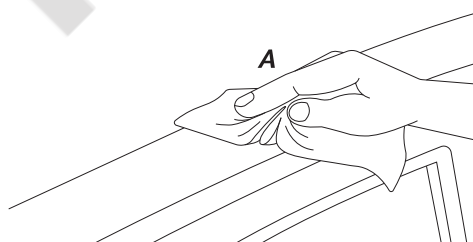

1

A Clean a thread hole.  
B Remove end caps from bars.

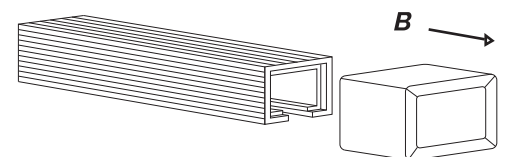

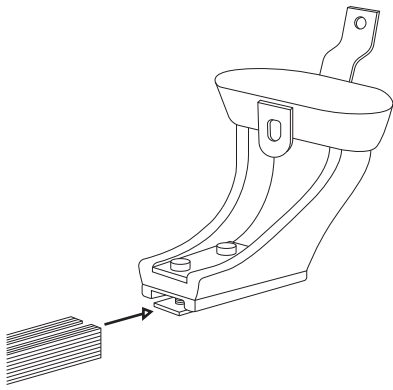

2 Remove end caps. Slide in foot into bars. Remember to use protective rubber pad on clamps.

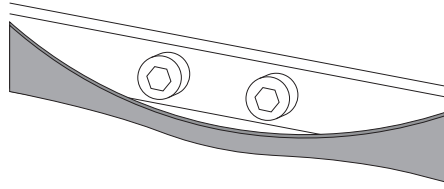

3 Open all vehicle doors. Carefully pull back rubber trim to expose fixation point. Where two mountings are provided, attach to the inner holes closest to the door centre posts.

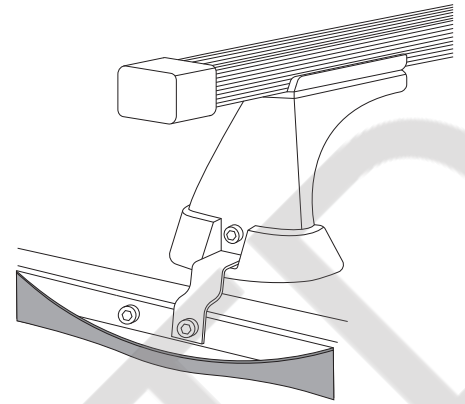

4 Locate and attach bars to vehicle using bolt previously removed. Tighten bolt.

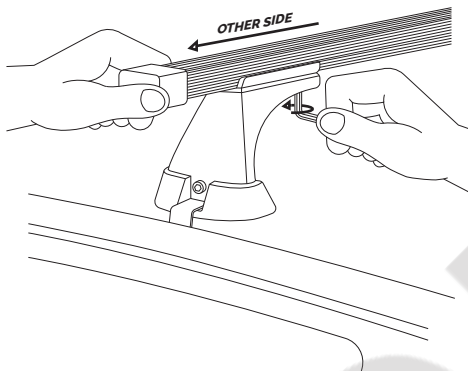

5 Pull the bar on the other side, hold it and screw tightly the handle to the bar in other side. Handles have to be as close to the centre of bar, as much as possible.

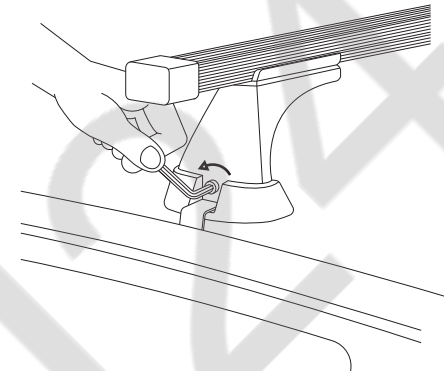

6 Adjust the cooper screw **ANTICLOCKWISE** of foot so that they touch the roof, door frame or both, this depends on the car.

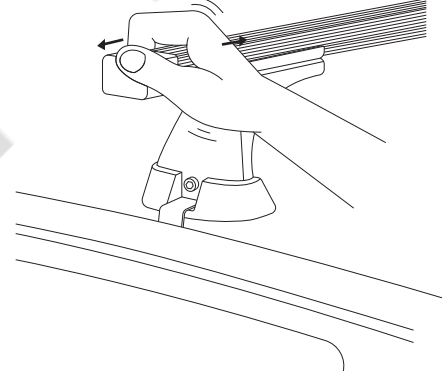

7 Check fitment is secure before using and also every 200 miles, to be sure the roof is stable, and whether the individual elements do not unscrewed.

**Note: Remember to use additional rubber and fill in visible slots underneath the bar (Aero and Dynamic bars only)**

*If the construction is loose, please repeat the operation, start by fitting the handles as close as possible to the middle of the bar.*

## Safety Notes

**You need to avoid:**



Quick Acceleration



Bad roads

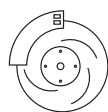

Heavy braking



Oversized loads

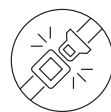

Improperly fastened loads



Uneven loading



Max load



Check fitment



### CONTACT

Email: [office@yogi24.co.uk](mailto:office@yogi24.co.uk)  
[www.yogi24.co.uk](http://www.yogi24.co.uk)  
[www.facebook.com/yogi24ltd](https://www.facebook.com/yogi24ltd)

### YOGI24 LTD

East Belfast Enterprise Centre, 68-72 Newtownards Road  
 BT4 1GW Belfast, Northern Ireland