

Fitting Instructions

Model: OKX

FIXED POINTS



Parts:

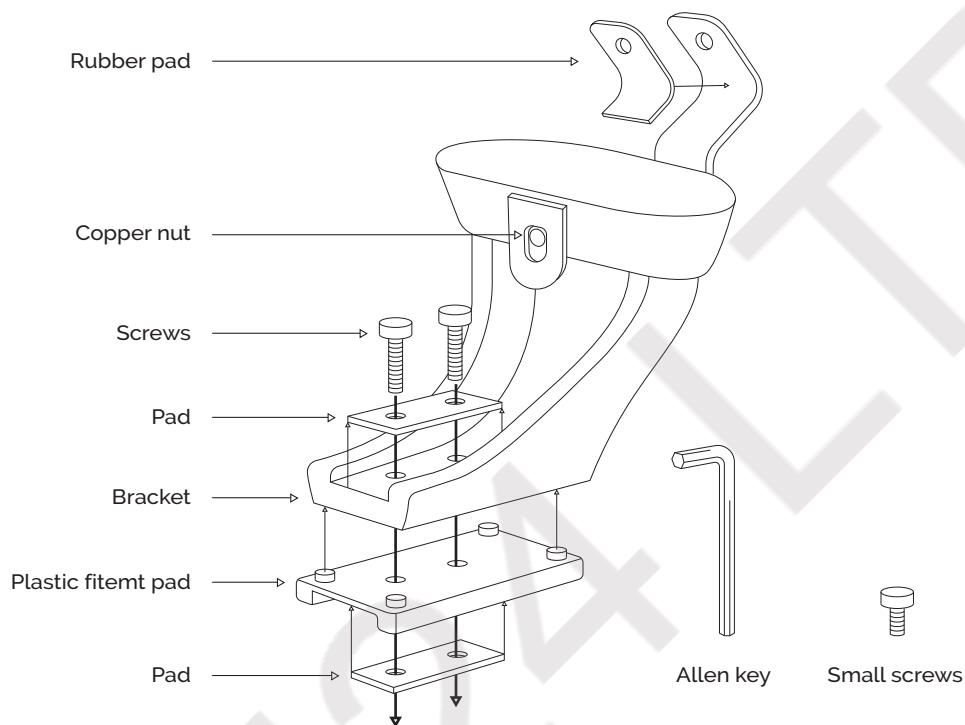

Bar types:

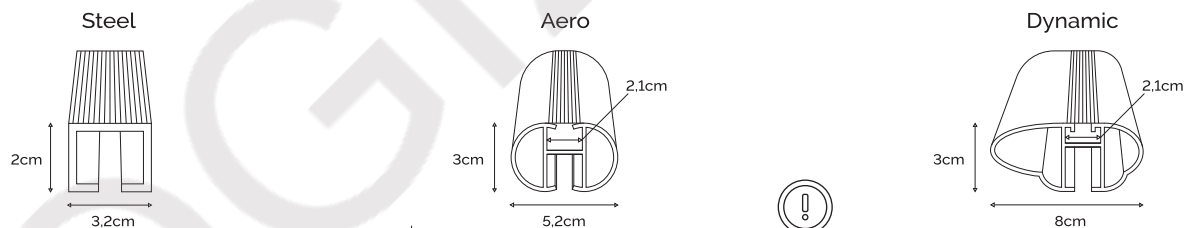

Please use additional rubber and fill in visible slots underneath the bar.

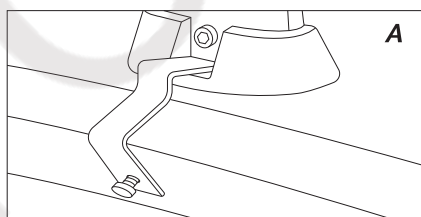

Open all vehicle doors, to reveal the mounting points

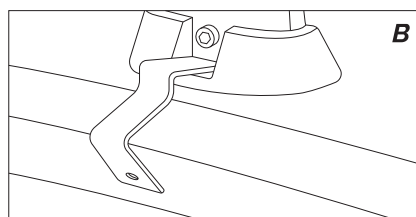

If the car has no mounting points, the handles are used as clamps

Manual:

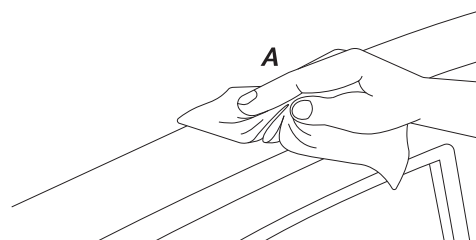

1

A Clean a thread hole.
B Remove end caps from bars.

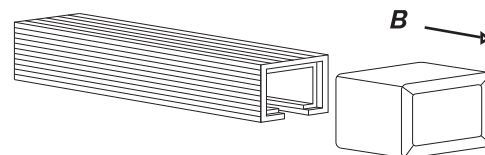

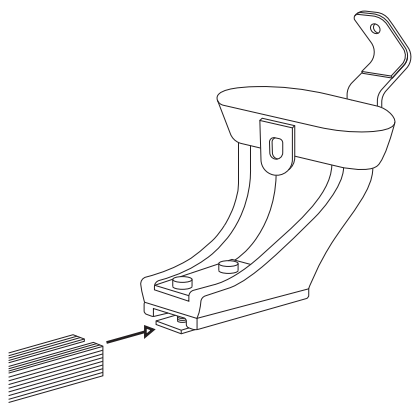

2 Remove end caps. Slide in foot into bars. Remember to use protective rubber pad on clamps.

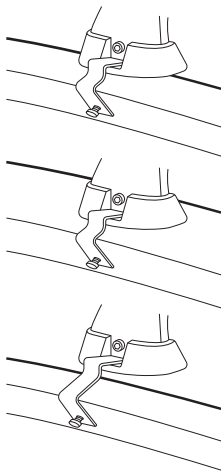

3 The feet of the handles is located on the roof, on the door frame or on the edge between them (depending on the shape of the roof)

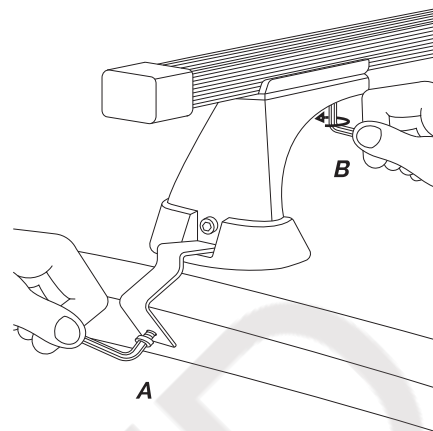

4 **A.** Use small screws for fixation of clamp to door frame, on both sides.
B. Using allen key screw the bracket tightly to the beam on one side.

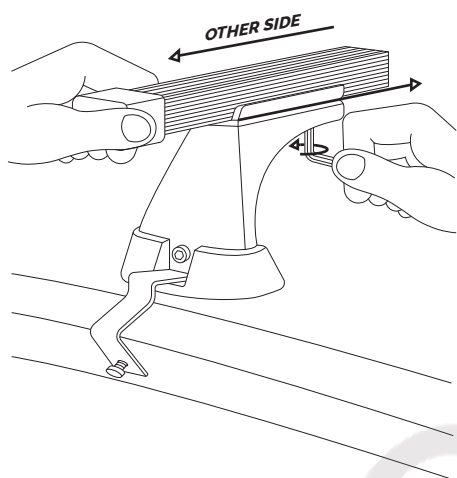

5 Pull the bar on the other side, hold it and screw tightly the handle to the bar in other side. Handles have to be as close to the centre of bar, as much as possible.

Note: Remember to use additional rubber and fill in visible slots underneath the bar (Aero and Dynamic bars only)

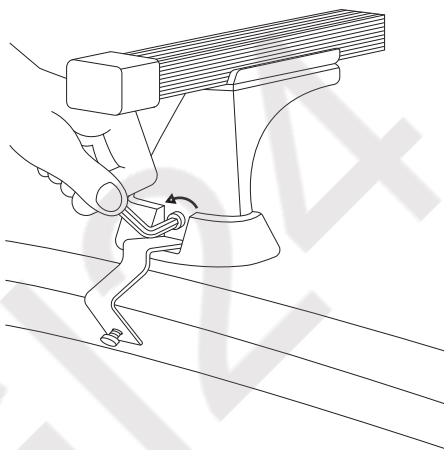

6 Adjust the cooper screw of foot so that they touch the roof, door frame or both, this depends on the car.

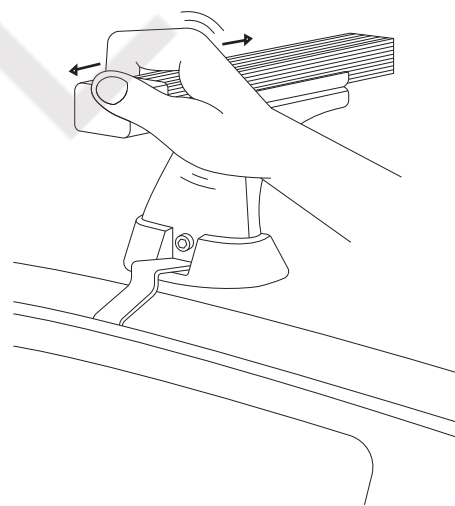

7 Check fitment is secure before using and also every 200 miles, to be sure the roof is stable, and whether the individual elements do not unscrewed.

If the construction is loose, please repeat the operation, start by fitting the handles as close as possible to the middle of the bar.

Safety Notes

You need to avoid:

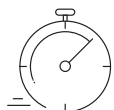

Quick Acceleration



Bad roads



Heavy braking



Oversized loads



Improperly fastened loads



Uneven loading



Max load



Check fitment



CONTACT

Email: office@yogi24.co.uk
www.yogi24.co.uk
www.facebook.com/yogi24ltd

YOGI24 LTD

East Belfast Enterprise Centre, 68-72 Newtownards Road
BT4 1GW Belfast, Northern Ireland